

77: Hub and bearing, M56

V70 (00-08), 2004, B5244S2, M56, L.H.D, YV1SW65S241436824, 436824

22/5/2013

**PRINT****77: Hub and bearing, M56****Rear wheel hub, replacing****Special tools:**
951 2050**Removing the rear wheel hub**

Raise the car.

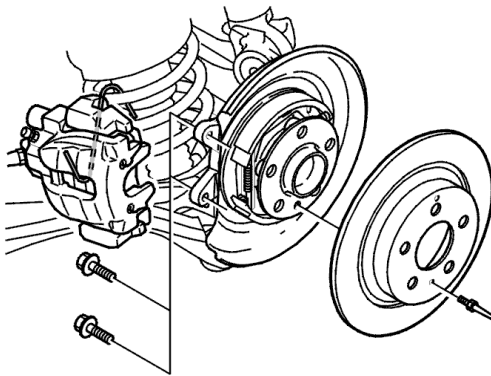

Remove

- the wheel
- ABS sensor and the cable from the wheel spindle
- the brake caliper mounting screws. Hang up the ABS line and the brake caliper. Use a piece of wire
- the locating pin for the brake disc
- the brake disc
- the holder for the ABS line on the wheel spindle.

Press up the control arm slightly. Use a mobile jack.

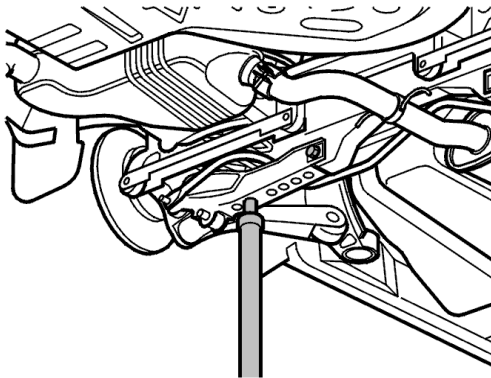

(The illustration displays the rear wheel hub schematically)

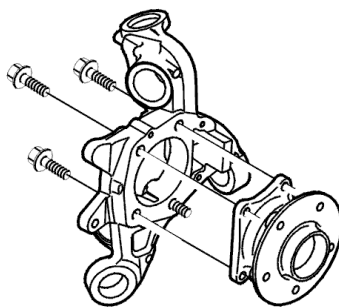

- the screws from rear wheel hub
- the rear wheel hub.

Note! The flange on the lower rear screw must be ground off as illustrated before it can be

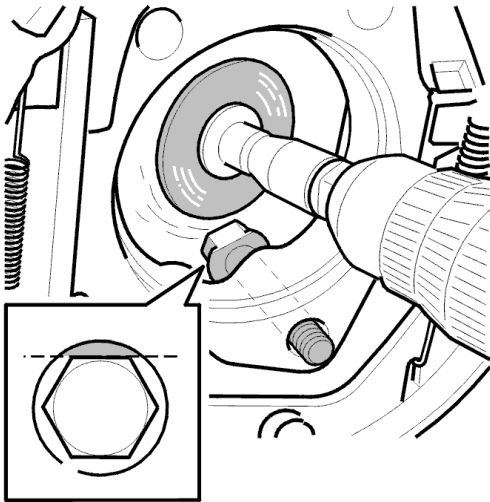

removed from the wheel spindle.

Installing the rear wheel hub

(The illustration displays the rear wheel hub schematically)

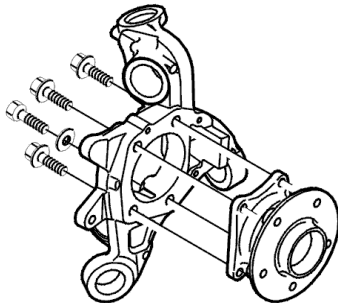

Note! Ensure that the hub and the wheel spindle mating surfaces are clean.

Install

- the rear wheel hub. Use new screws and torque wrench with ring wrench kit. Tighten crosswise. Tighten to **20 Nm**. Then tighten to **65 Nm**. Finally angle-tighten **60°**. Use bevel protractor 951 2050 . In the event of difficulty using the bevel protractor, see: Screwed joint, torque/angle tightening .

Note! The screw without a flange has a washer which is included in the kit. Position the screw in the rear lower screw hole.

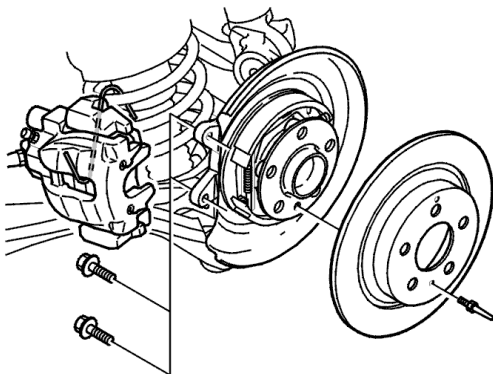

- the brake disc
- the locating pin for the brake disc. Tighten the locating pin. Tighten to **10 Nm**
- the brake caliper. Use new screws. Tighten to **60 Nm**
- the ABS sensor.

Note! Ensure that the sensor seat in the wheel spindle is completely clean. Clean the ABS sensor with a soft brush. Tighten the sensor. Tighten to 10 Nm.

- the ABS-cable holder
- the wheel. See Installing wheels .

22/5/2013

PRINT